

WAR DEPARTMENT

TECHNICAL MANUAL

OF

ORDNANCE MAINTENANCE

THOMPSON SUBMACHINE GUN,
CAL. .45, M1928A1

March 1, 1942



ORDNANCE MAINTENANCE, THOMPSON SUBMACHINE
GUN, CAL. .45, M1928A1Prepared under direction of the
Chief of Ordnance

	Paragraphs
SECTION I. Introduction.....	1
II. General description.....	2-4
III. Inspection.....	5-12
IV. Maintenance and repair.....	13-18
V. References.....	19-20
	Page
INDEX TO TEXT.....	23-25

SECTION I

INTRODUCTION

	Paragraph
Scope.....	1

1. **Scope.**—This manual is published for the information and guidance of ordnance maintenance personnel. It contains detailed instructions for inspection, disassembly, assembly, maintenance, and repair of the Thompson submachine gun, cal. .45, M1928A1, supplementary to those in the Field and Technical Manuals prepared for the using arm. Additional descriptive matter and illustrations are included to aid in providing a complete working knowledge of the matériel.

SECTION II

GENERAL DESCRIPTION

	Paragraph
Description.....	2
Mechanism.....	3
Operation.....	4

2. **Description.**—The Thompson submachine gun, cal. .45, M1928A1 (figs. 1 and 2), is an aircooled, blowback-operated, magazine-fed weapon. It is designed to be fired from the shoulder of the gunner similarly to a rifle, and is used as an auxiliary weapon by the United States Army, Navy, and Marine Corps. The fire control lever of the gun can be set for either full automatic or semiautomatic



RA PD 4106

FIGURE 1.—Thompson submachine gun, cal. .45, M1928A1—right side view with 20-round magazine.

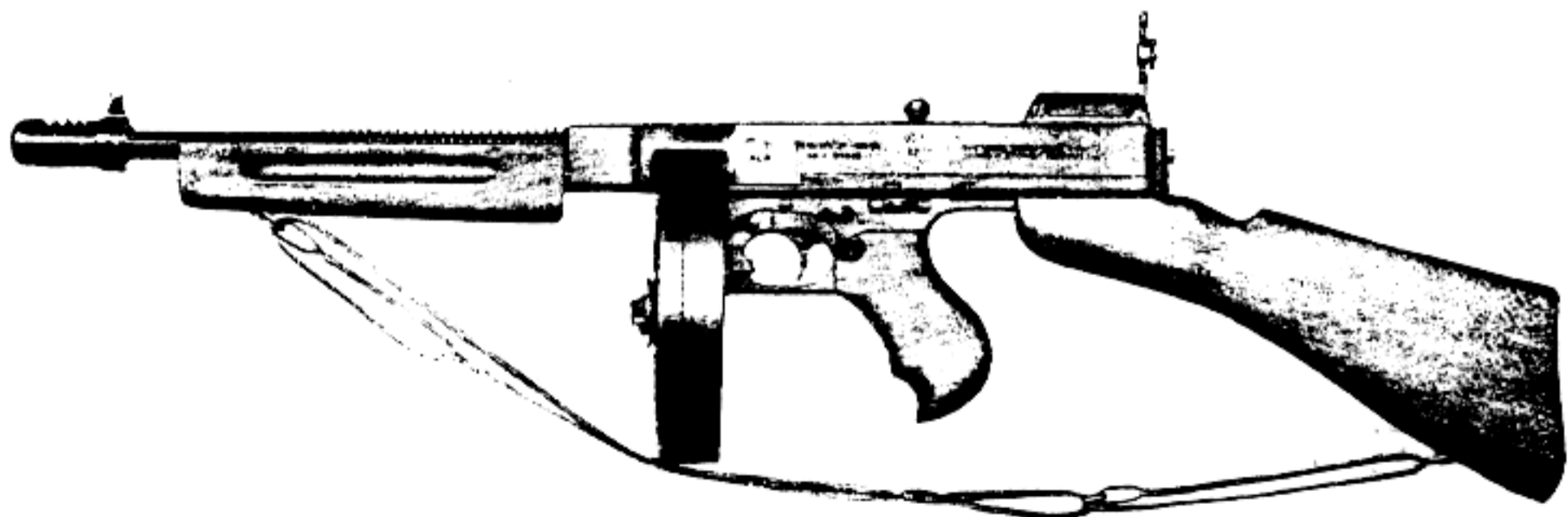

RA PD 4105

FIGURE 2.—Thompson submachine gun, cal. .45, M1928A1—left side view with 50-round magazine.

fire. Two types of magazines, having capacities of 20 and 50 cartridges respectively, may be used.

3. Mechanism (fig. 3).—The gun is composed of two distinct groups, the frame with its attached and contained parts, and the receiver with its attached and contained parts. The frame group consists of the frame, to which are attached the butt stock assembly and rear wooden grip. The frame contains the trigger and sear groups, the magazine catch, and the fire control mechanism. The receiver group consists of the receiver, to which are attached the barrel with front sight and recoil ("Cutts") compensator, the wooden foregrip and rear sight. Within the receiver are the bolt, lock, actuator, recoil and buffer mechanisms.

4. Operation.—The cycle of operation is as follows: With the safety at "Fire," the fire control lever at "Single" and the bolt retracted and held by the sear, the trigger is pulled. The bolt, released by the sear, moves forward under pressure of the recoil spring. The end of the bolt comes in contact with the base of a cartridge and forces it out of the magazine into the chamber of the barrel, where the extractor snaps over the rim of the cartridge. The forward movement of the bolt cams the lock downward into the locking grooves of the receiver so the bolt and receiver are completely locked together in the forward position before the hammer forces the firing pin to strike the cartridge. Pressure of the exploding cartridge against the end of the bolt, transmitted to the lock, forces the lock upward, unlocking the bolt and drives it backward with the actuator. As the bolt moves backward, the empty cartridge case is extracted and ejected, the recoil spring is compressed against the buffer pilot collar and the sear engages in one of the two notches of the bolt, completing the cycle. If the fire control lever is set at "Full Auto," the sear will remain depressed and will not engage the bolt on the backward stroke. Under this condition, the gun will continue to function automatically as long as the trigger is retracted or until the magazine is empty. For detailed description of operation and functioning, refer to FM 23-40.

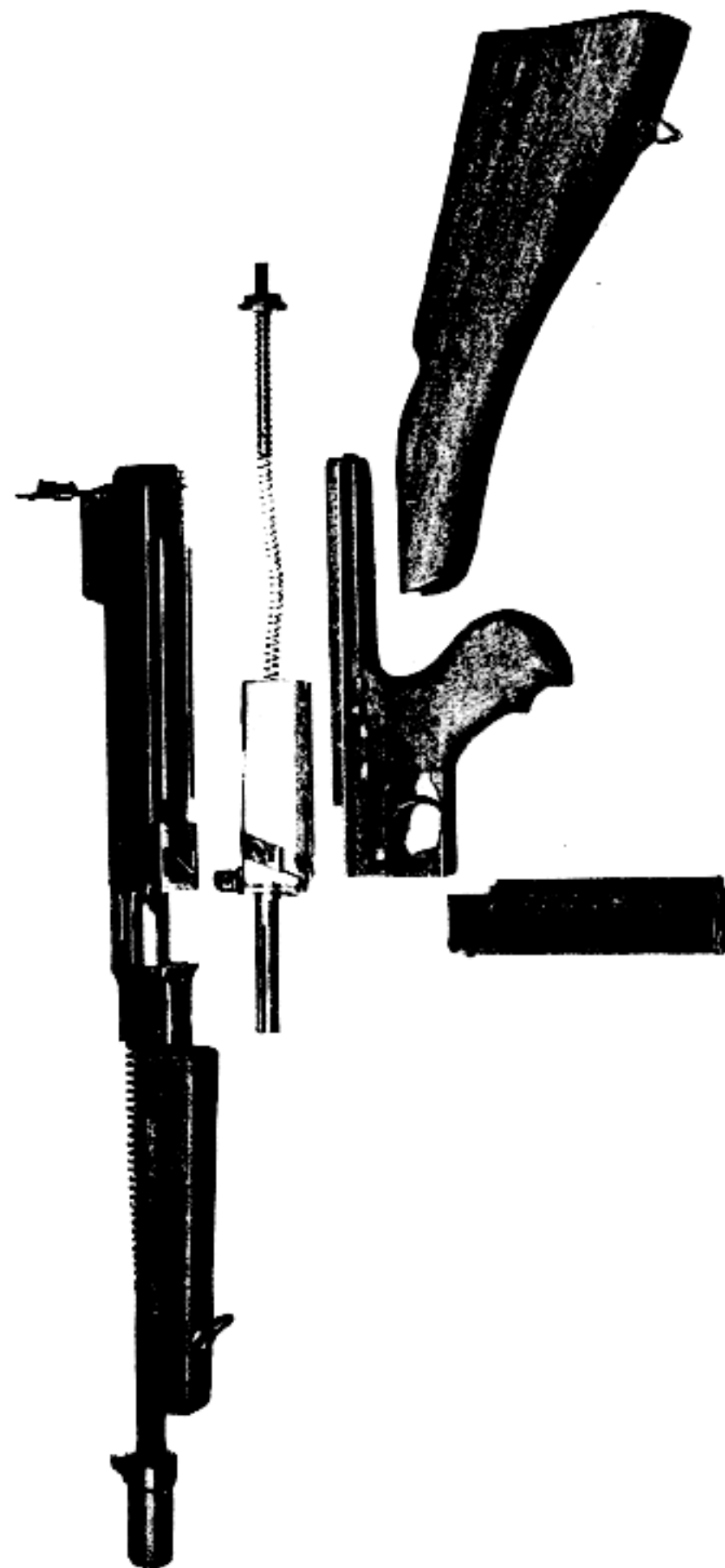

FIGURE 3.—Thompson submachine gun, cal. .45, M1928A1—groups.

SECTION III

INSPECTION

	Paragraph
General	5
Inspection report	6
Tools for inspection	7
Gun as a unit	8
Frame group	9
Receiver and barrel groups	10
Box magazine	11
Drum magazine	12

5. **General.**—*a.* Inspection is for the purpose of determining the condition of the matériel, whether repairs or adjustments are required, and the remedies necessary to insure that the matériel is in serviceable condition.

b. Before inspection is begun, the equipment should be thoroughly cleaned to remove any fouling, dirt or other foreign matter, which might interfere with its proper functioning. For instructions in care and cleaning, and materials used, refer to FM 23-40, section on "Care and Cleaning"; section IV of this Technical Manual, TM 9-850, and SNL K-1.

6. **Inspection report.**—The procedure to be followed relating to inspection and maintenance is contained in TM 9-1100, "Ordnance Maintenance Procedure—Matériel Inspection and Repair."

7. **Tools for inspection.**—Tools used for inspection of the gun are those furnished for disassembly, assembly and repair. They are included in the accessories referred to in FM 23-40, and listed in SNL A-35.

8. **Gun as a unit.**—*a.* Check gun for general appearance, metal parts for scratches, rust, and wear, and wooden parts for cracks and nicks. Check firmness of magazine in grooves, and action of magazine catch. Check rigidity of rear sight base on receiver, front sight on compensator, compensator on barrel, butt stock and grips on frame and receiver, and sling swivels on stock and foregrip. Inspect heads of screws for burrs. Remove magazine and check smoothness of bolt and trigger action while retarding actuator movement by hand so the bolt will not fly forward on an empty chamber.

Caution: Unless magazine is removed, the bolt, if released, will fire a cartridge from a loaded magazine, as this gun fires on forward stroke of the bolt.

b. If possible and practicable, fire several rounds from the gun. Observe action of the weapon and analyze the cause of any malfunction.

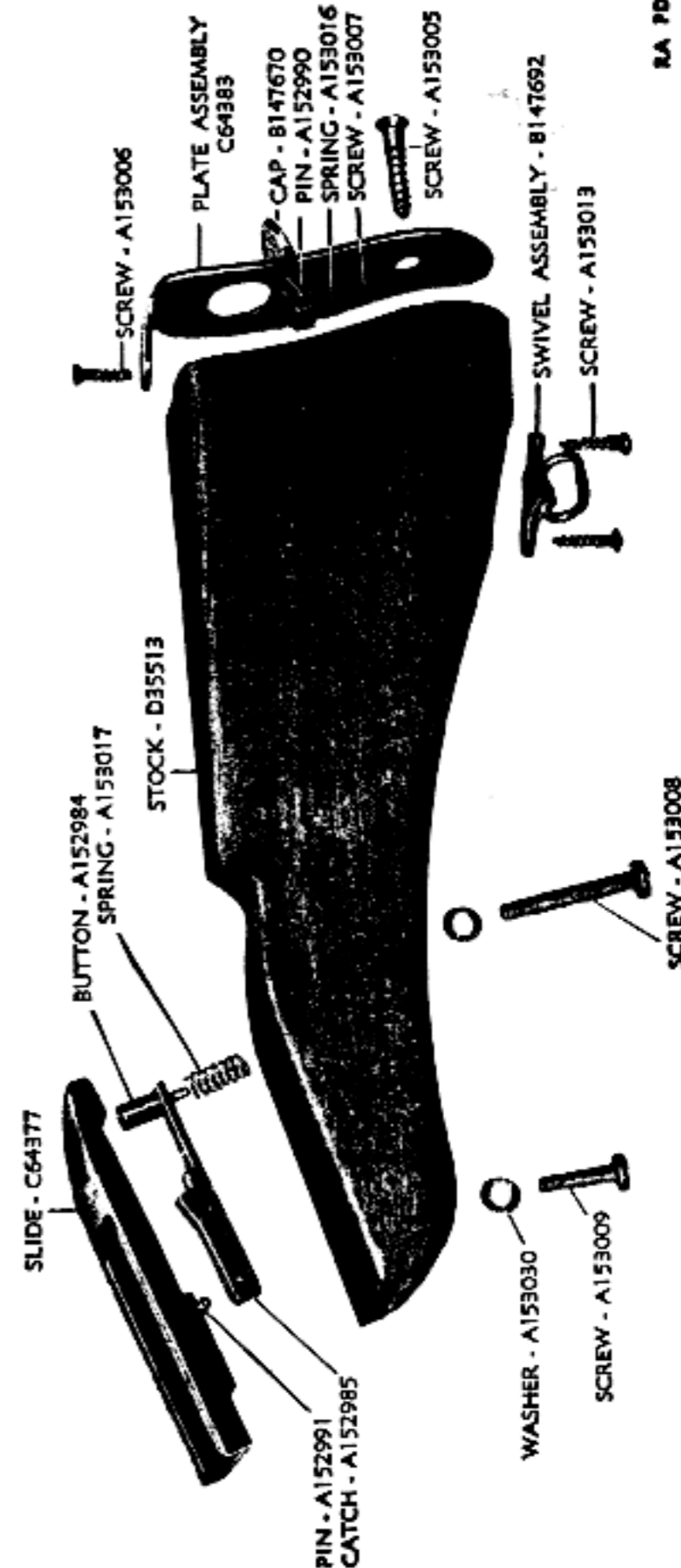

RA PD 9540

FIGURE 4.—Thompson submachine gun, cal. .45, M1928A1—butt stock disassembled.

9. **Frame group.**—*a.* To inspect the frame group, first remove the butt stock assembly. Pull the actuator to rear until the bolt is caught and held by the sear. With the bolt in rearward position, set the fire control lever (rocker pivot) at "Full Auto" and the safety at "Fire" and allow bolt to go forward slowly by pulling the trigger and retarding the actuator by hand.

Caution: It is necessary that the fire control lever and the safety be set as described before withdrawing the frame from the receiver. Otherwise the sear and rocker will not be depressed and serious damage can result to the mechanism if the frame is moved under these conditions.

b. **Butt stock assembly (fig. 4).**—Check action of the butt stock catch, and nose of catch for wear and burrs. Remove the screws and lift out the assembly. Inspect butt stock catch spring for functioning, fracture and set. Free length of spring (A153017) is $.75 + .02$ in. Drive out the butt stock catchpin and remove catch. (To remove the catch button, file pin to round and drive out.) Inspect the butt stock slide for burrs and dents. Remove the butt stock plate to inspect action of trap spring. If necessary, remove the spring and drive out trap pin. (The bracket is riveted to the butt plate.) Remove the sling swivel screws and lift out the swivel plate. If necessary, spring the swivel from the plate.

c. **Frame (fig. 5).**—Inspect the frame for cracks in the metal and dents and burrs on corners, grooves and surfaces of stock slideways and magazine grip. Inspect the butt stock catch notch for wear and burrs. Inspect the safety and the pivot holes in the frame for wear. If the rear grip is loose, inspect screw threads in frame and on screw for wear, and the screw for straightness. Inspect the frame latch notch in rear of frame for wear and burrs.

d. **Magazine catch assembly.**—Unless necessary, do not remove the magazine catch from the frame as the spring is apt to be damaged. If removed, check spring for functioning, fracture and set. Free length of spring (A153021) is $.85 + .02$ in. Look for foreign matter in spring aperture. Check movement of the magazine catch in the frame without spring. Check the catch nose for wear and burrs. Check pin for wear and firmness in the latch. (Head of pin is riveted into latch.)

e. **Safety.**—Check movement of the safety in the frame without pivot plate. Inspect bearing surfaces for wear and burrs.

f. **Rocker.**—Check movement of the rocker on rocker pivot. Inspect for wear and burrs on contacting surfaces.

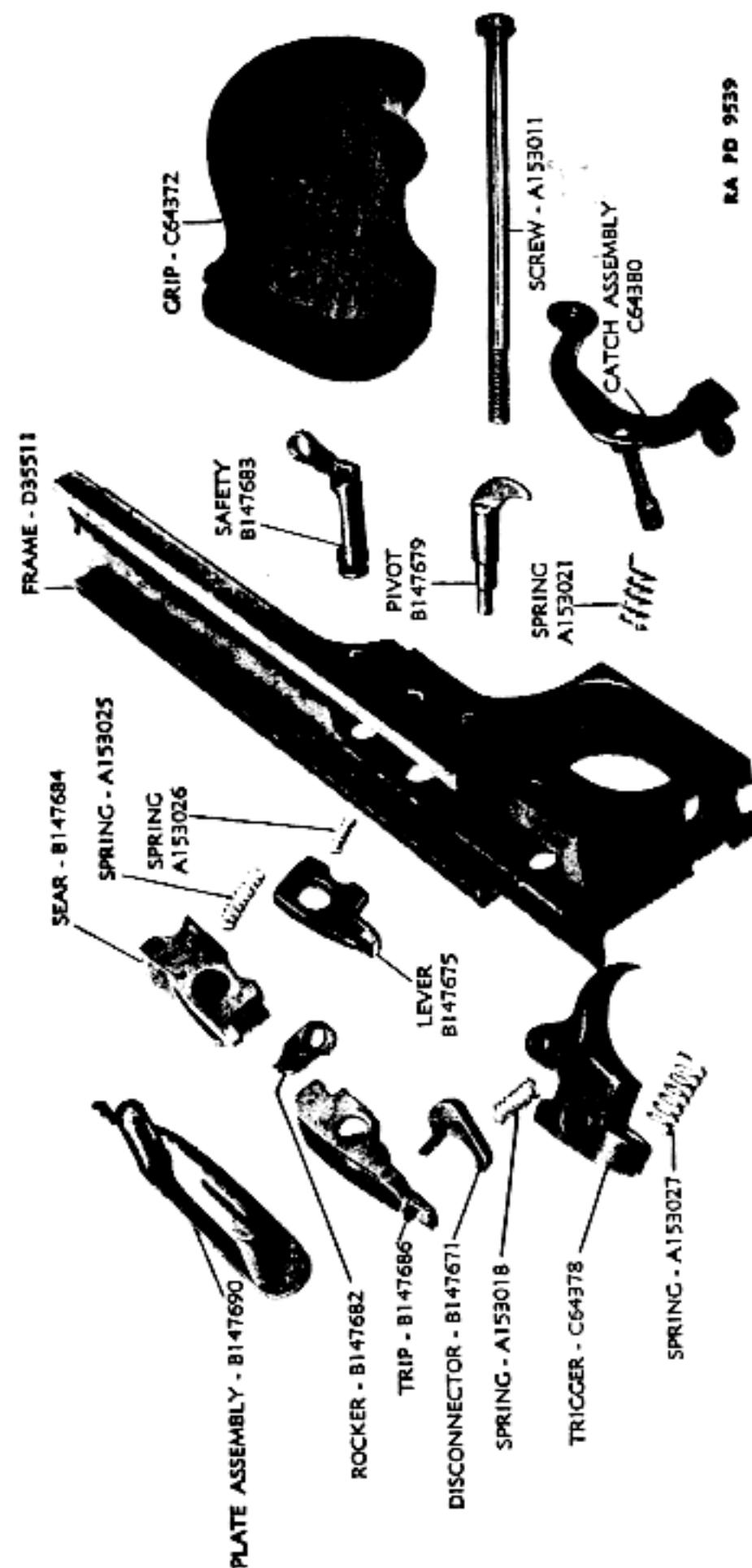

RA PD 9539

FIGURE 5.—Thompson submachine gun, cal. .45, M1928A1—frame group disassembled.

g. Rocker pivot.—Check movement of the rocker pivot in the frame without pivot plate. Inspect bearing surfaces for wear and burrs.

h. Pivot plate assembly.—Check the pivot plate short and long springs for functioning, fracture, and set. Inspect pivot pins for wear and firmness in the plate. (Pin heads are riveted into plate.)

i. Sear group (fig. 5).—Check sear for retention of the bolt. Inspect the sear for wear and burrs on nose and contracting surfaces, and for foreign matter in spring aperture. Check movement of the sear with sear lever on the pivot. Check sear spring for functioning, fracture, and set. Free length of spring (A153025) is $.765 \pm .02$ in. Inspect sear lever for wear and burrs on contacting surfaces and for foreign matter in spring aperture. Check sear lever spring for functioning, fracture, and set. Free length of spring (A153026) is $.43 \pm .01$ in.

j. Trigger group (fig. 5).—Inspect the trigger for wear in pivot hole and disconnecter pivot hole, and for deformation of tip. Check action of trigger with disconnecter and trip on trigger pivot. Check trigger spring for functioning, fracture, and set. Free length of spring (A153027) is $.65 \pm .01$ in. Inspect disconnecter for wear on pin and wear and burrs on contacting surface. Check disconnecter spring for functioning, fracture, and set. Free length of spring (A153018) is $.50 \pm .01$ in. Inspect trip for wear and burrs on contacting surfaces.

k. Assemble the sear and trigger mechanisms in the frame and try action of the trigger with the rocker in each position.

10. Receiver and barrel groups (fig. 6).—*a.* To inspect the receiver group, remove the buffer pilot and pad together with the recoil spring from the receiver. With the receiver inverted, move the actuator back and forth to inspect movement of the lock in the grooves of receiver and bolt. Take out the bolt group, actuator and lock, and remove oiler assembly.

b. Receiver group.—Inspect the receiver for wear and burrs on frame slideways and lock camming surfaces, and the bullet ramp for wear and fouling. Inspect corners and edges for dents and burrs and the magazine retaining grooves and actuator groove for wear. Inspect the buffer pilot aperture for wear. Inspect the frame latch for wear and aperture for wear and foreign matter. Check latch spring for functioning, fracture, and set. Free length of spring (A153020) is $.45 \pm .01$ in. Check the ejector for firmness in receiver, and inspect the point for wear and alignment. Never try to remove the ejector from receiver with the bolt in the forward position.

c. Barrel group.—Inspect the barrel as a unit from the standpoint of serviceability.

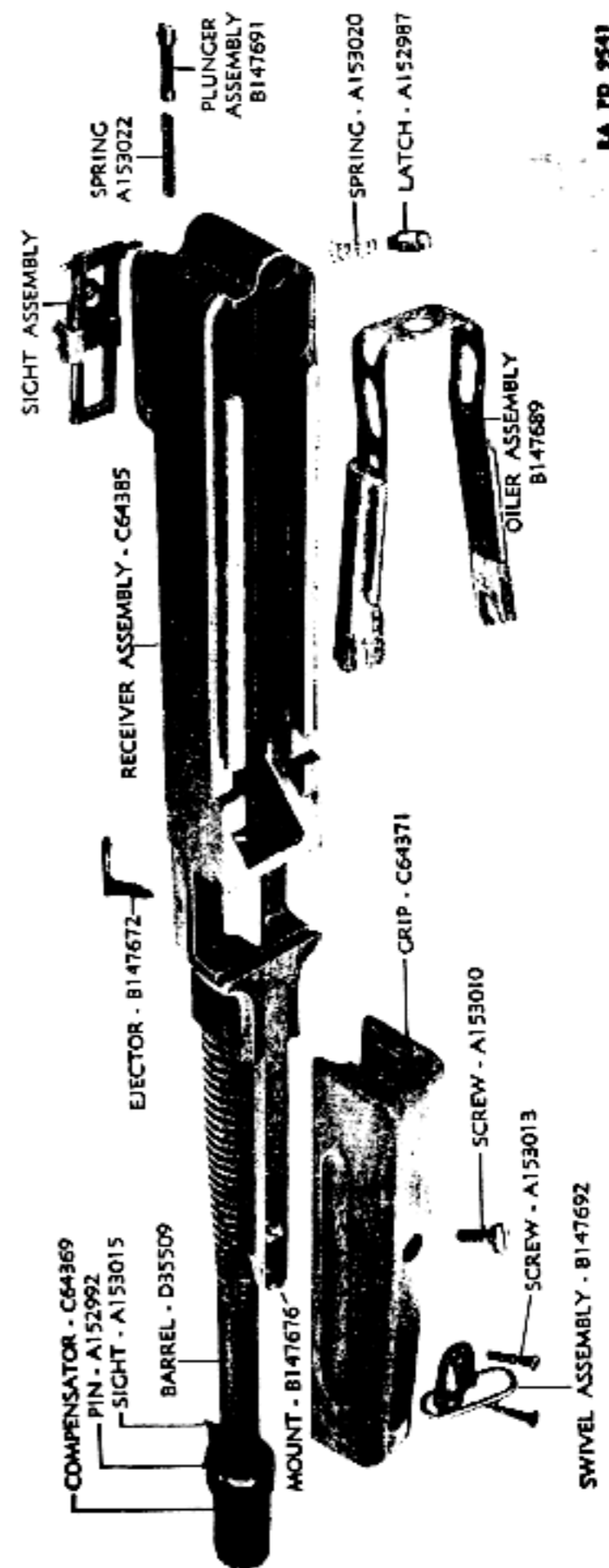

FIGURE 6. — Thompson submachine gun, cal. .45, M1928A1— receiver and barrel group (disassembled).

(1) *Inspection of the barrel group as a unit.*—Check firmness of the barrel in receiver. Inspect the annular radiator grooves for presence of foreign matter, dents and burrs. Do not remove the barrel from the receiver unless necessary to replace. For removal of the barrel, refer to paragraph 14 *c* (2) (b). Inspect for loose front sight, alinement of sight blade, burrs and shine on tip. Inspect recoil ("Cutts") compensator for firmness on the barrel and for any foreign matter in gas escape slots. Do not remove compensator or sight unless necessary. To remove, drive out pin, drive sight rearward and unscrew compensator with a strap wrench.

(2) *Inspection of the barrel for serviceability.*—(a) With the firing mechanism removed from the receiver, hold the barrel up to the light, and inspect chamber and bore thoroughly for wear, pits and bulges. To facilitate inspection, place piece of white paper or rag in the receiver so as to reflect light into the bore, then turn the barrel slowly so the light follows the circumference of the bore. Untrueness and bulges in the bore can thus be detected more easily.

(b) A barrel containing small pits, but having sharp and uniformly distinct lands, and free from bulges, will be sufficiently accurate to be serviceable. This condition, however, naturally implies that the barrel has been neglected and its period of serviceability will, therefore, be materially lessened.

(c) A barrel containing a bulge is unserviceable and should be scrapped. This condition is indicated by a shadowy depression or dark ring in the bore and may often be noticed by a raised ring on the barrel surface.

(d) A barrel with the lands worn away for a considerable distance from the breech end of the bore, and/or pitted to the extent that the sharpness of the lands is affected, or if it has a pit or pits in the lands or grooves large enough to permit the passage of gas past the bullet (a pit the width of a land or groove and $\frac{3}{8}$ to $\frac{1}{2}$ in. in length or longer) is, or soon will be, too inaccurate for serviceability and should be scrapped.

d. Foregrip group.—Inspect the foregrip for cracks and rigidity. Remove foregrip from mount and inspect screw threads on screw and in the mount for burrs. Remove the mount by driving it forward, then inspect slide blades and grooves in the receiver. Check the mount for alinement. Inspect the sling swivel and plate.

e. Rear sight group (fig. 7).—Check for missing or loose base rivets in the receiver. Do not remove base unless necessary. Inspect base for breaks and dents. Check action of sight leaf assembly with plunger and spring. Inspect all parts for rust, alinement,

deformation and presence of foreign matter. Check operation of windage screw and sight slide and sight slide catch. Do not remove unless necessary. (To remove, drive out sight base pin and remove sight leaf assembly.) Remove plunger and plunger spring. Inspect point of plunger for wear, plunger pin for deformation and spring for functioning, fracture, and set. Free length of spring (A153022) is $1.20 \pm .02$ in. Check for missing or loose sight slide stop pin. Do not disassemble unless necessary. (To disassemble, drive out pin and remove slide. Drive out windage screw collar pin and remove collar

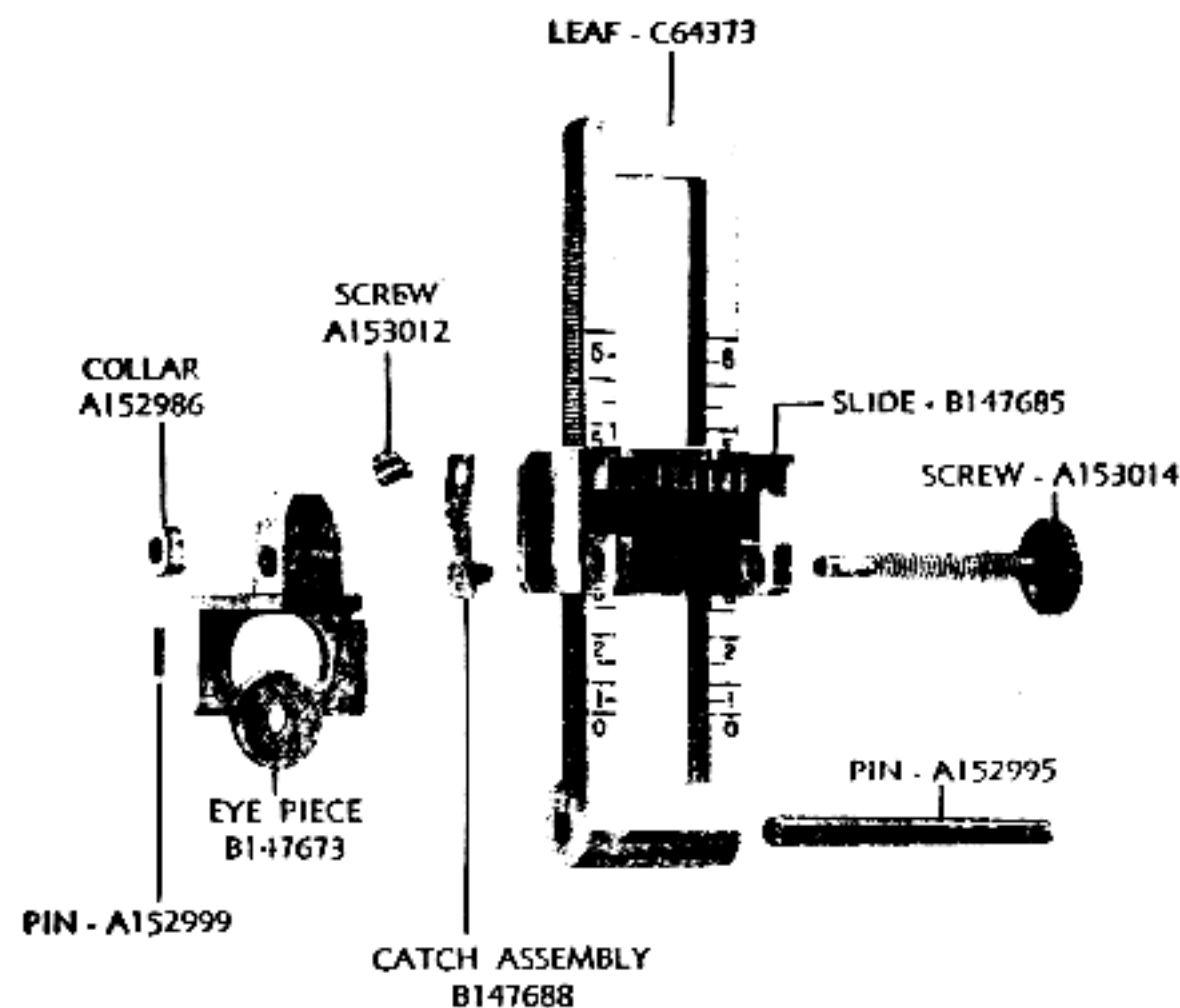

RA PD 9542

FIGURE 7.—Thompson submachine gun, cal. .45 M1928A1—rear sight group disassembled.

and windage screw and the eye piece.) Inspect the eye piece slides and the slide grooves for burrs and wear.

f. Bolt group (fig. 8).—Bolt surfaces should be polished and free from rust, foreign matter, or roughness. Inspect sear notches, edges, corners and grooves for burrs, wear and dents. Examine fired cartridge cases for indications of set back primer due to worn face of bolt or enlarged firing pin hole. Inspect the bolt face for deformation and firing pin hole for enlargement. Inspect head of T-slot for

burs and wear caused by the rocker. Remove the extractor, taking care not to spring more than necessary to clear the lug. Inspect the extractor for set and deformation, and claw for wear. Remove the hammer pin, hammer, firing pin and firing pin spring. Check hammer pin for looseness and wear. Check hammer for wear and burs in pin hole and on contacting surfaces. Inspect firing pin head and nose for wear and burs. Check firing pin spring for functioning, fracture, and set. Free length of spring (A153019) is $2.50 + .05$ in.

g. Lock.—Inspect lock for wear and burs on sliding surfaces. Check movement of lock in actuator and receiver locking grooves.

h. Actuator.—Inspect actuator for wear and burs on sliding surfaces, recoil spring aperture for foreign matter and actuator head for fracture or deformation.

i. Buffer group.—Inspect buffer pilot for alinement, deformation, and wear. Inspect buffer pad for deformation and wear.

j. Oiler group.—Check oiler for fit and spring retention in receiver. Sides of oiler should lie flush to sides of receiver. Check oiler pads for fraying and absorption.

k. Recoil spring.—Inspect recoil spring for functioning, deformation, fracture, and set. Free length of spring (A153024) is $10.00 + .25$ in. Care must be taken in removing and replacing this spring, as it is apt to fly loose and become twisted between actuator and pilot, resulting in deformation which may cause binding on compression stroke of bolt.

11. **Box magazine (20 rounds)** (fig. 9).—*a.* Check box magazine for fit and retention in receiver.

b. Depress follower and note smoothness of operation and tension of spring. Insert two or three dummy cartridges in magazine and attach magazine to gun. Operate the piece by hand and observe loading, extraction, and ejection. Note also whether the magazine follower (when the magazine is empty) lifts the trip sufficiently to force the disconnecter from under the sear lever and allow the sear to catch the bolt and hold it in the open position.

c. Inspect magazine tube for dents, cracks, deformed lips, and foreign matter. Check follower pin for deformation, wear and burs, and magazine spring for functioning, fracture, and set. Free length of spring is $8.00 + .20$ in.

12. **Drum magazine (50 rounds)** (fig. 10).—*a.* Check drum magazine for fit and retention in receiver.

b. Remove winding key and note its condition. Remove cover and check cover guide, slide and rivets. Rotate the rotor, noting the

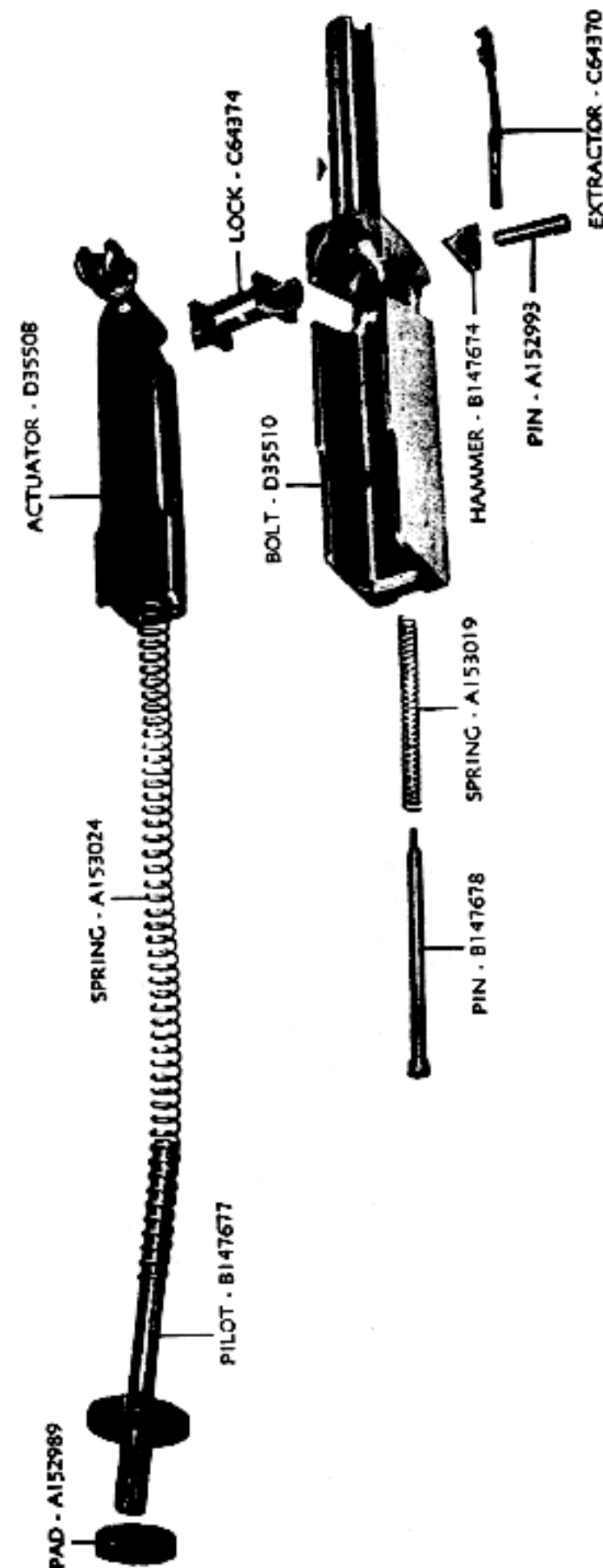

RA PD 9543

FIGURE 8.—Thompson submachine gun, cal. .45, M1928A1—bolt group disassembled.

16

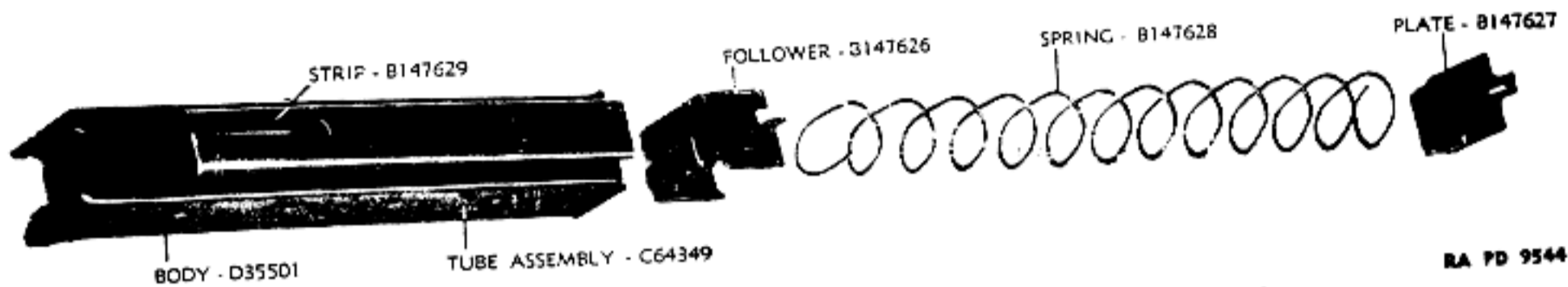

RA PD 9544

FIGURE 9.—Thompson submachine gun, cal. .45, M1928A1—20-round magazine disassembled.

17

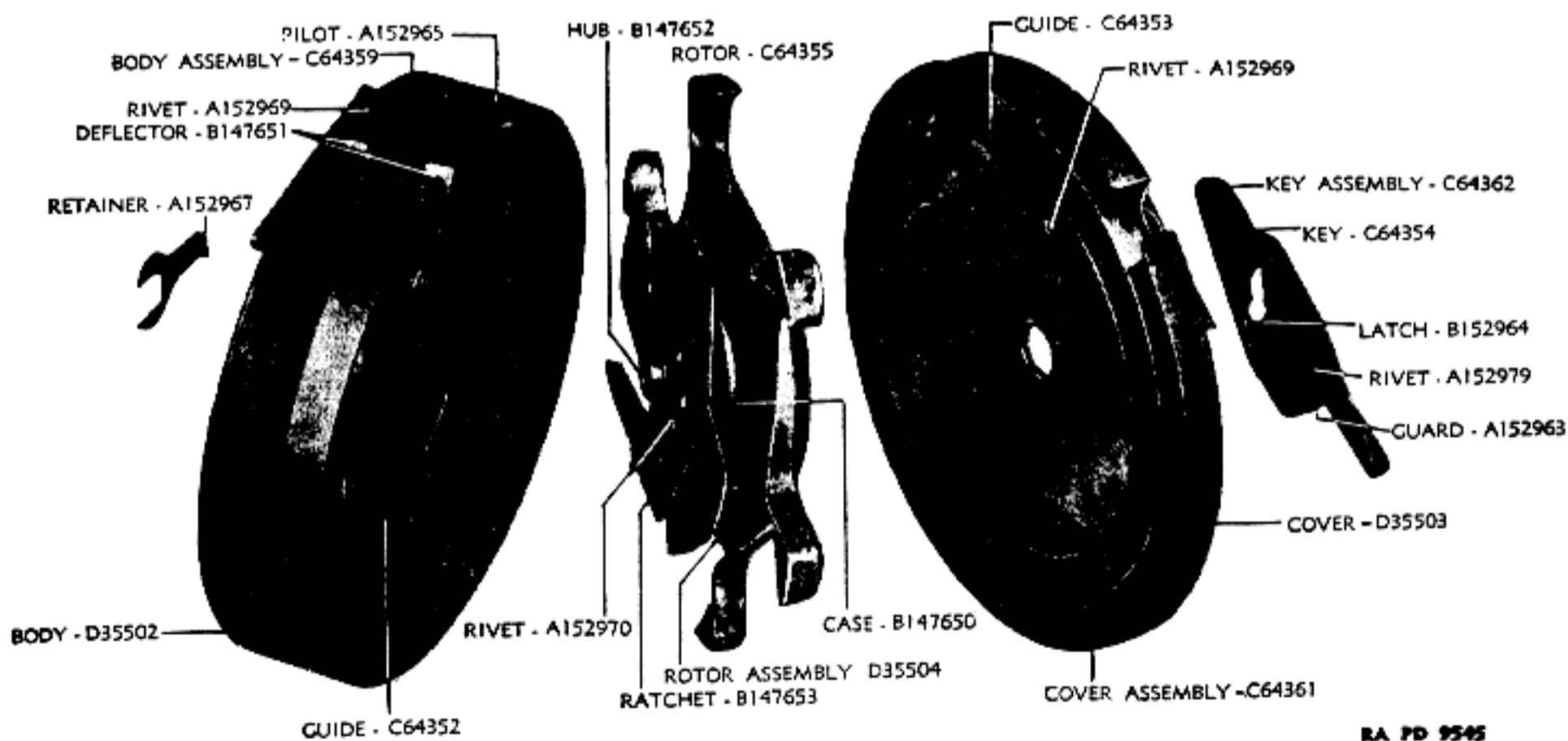

RA PD 9545

FIGURE 10.—Thompson submachine gun, cal. .45, M1928A1—50-round magazine disassembled.

action of the rotor spring. Further test the magazine by forcing the finger of the rotor standing nearest the feedway in the opposite direction to its normal rotation, and insert five dummy cartridges (one resting in the feedway). Replace cover and winding key and increase tension of rotor spring by turning the winding key one click. Insert the magazine and operate the piece rapidly by hand and observe loading, extraction, and ejection.

c. Inspect magazine body and cover for deformation and dents. Check guides in cover and body for deformation, and deflector for looseness and wear. Check key and retainer for deformation, and magazine catch grip in body for deformation and burrs. Do not disassemble rotor and spring case unless necessary, as they are riveted together.

SECTION IV

MAINTENANCE AND REPAIR

	Paragraph
General.....	13
Instructions for maintenance and repair.....	14
Care and cleaning.....	15
Care and cleaning in Arctic climates.....	16
Lubrication.....	17
Matériel affected by gas.....	18

13. **General.**—*a.* The maintenance and repair of the Thompson submachine gun, cal. .45, M1928A1, as covered in this manual is primarily a replacement of worn or broken parts. General disassembly and assembly of the gun is covered in FM 23-40.

b. Where parts, assemblies, or parts of assemblies are broken or worn so as to render them unserviceable, they must be replaced from stock. Often only parts of assemblies will be broken or worn; where it will take more time to remove the serviceable parts from the assembly than the parts are worth, the assembly should be scrapped. Parts do not always interchange and should be assembled by selection.

c. In general, maintenance operations are of a first aid nature, performed by qualified ordnance personnel with only the limited tool facilities afforded by repair trucks, or by semipermanent shops at posts or camps, or by an inspector while making a regular inspection.

14. **Instructions for maintenance and repair.**—*a.* *Burs on screws and smooth surfaces.*—Remove burs from screw heads, threads and like surfaces with a fine file, and chase out damaged threads with a die if available. Remove the burs from smooth contacting surfaces with a fine grained sharpening stone or emery cloth, and finish with crocus cloth. Polish rounded contacting surfaces with crocus cloth. Care should be observed to file and stone evenly and lightly, removing

no more metal than is necessary. For materials employed in removing rust, cleaning and preserving, and the limits of their proper use, refer to TM 9-850.

b. Frame group.—(1) *Butt stock, assembly.*—If the butt stock is not held rigidly to the frame by the slide or catch, the faulty parts should be replaced.

(2) *Frame.*—When the frame is damaged to the extent that improper functioning of the gun results, it should be replaced.

(3) *Magazine catch, assembly.*—If the magazine catch does not hold in magazine firmly, it should be replaced. Check to see if the fault lies in the magazine.

(4) *Rocker and rocker pivot.*—The rocker or rocker pivot should be replaced if worn to the extent that automatic firing occurs with the rocker pivot set at "Single."

(5) *Sear, trigger and pivot plate groups.*—(a) When the bearing surfaces on the sear, trigger and the pivot plate pins become worn to the extent that malfunctioning of the gun results, the worn part or parts should be replaced.

(b) If either spring finger on the pivot plate becomes set or broken, replace the pivot plate.

c. Receiver and barrel groups.—(1) *Receiver group.*—(a) A receiver damaged to the extent that malfunctioning of the gun results should be replaced.

(b) A worn ejector should be replaced.

(c) If the frame latch or aperture becomes worn so that the frame is not securely locked to the receiver, the latch or receiver should be replaced.

(2) *Barrel group.*—(a) If it is determined that the barrel is unserviceable by inspection as prescribed in paragraph 10 c (2), the barrel should be replaced.

(b) To remove barrel, disassemble the gun, wedge a block of hard wood in receiver to prevent springing of the side, clamp receiver in a vise with leather jaws and unscrew barrel from receiver, using a strap wrench. If barrel is to be scrapped, a pipe wrench may be used.

(c) When it is determined to replace the barrel, the recoil compensator and front sight, if in good condition, should be removed from the defective barrel for assembly to the new barrel.

(3) *Rear sight group.*—If the rear sight has been broken or bent out of line, the damaged parts or the entire leaf assembly should be replaced.

(4) *Bolt group.*—(a) If the face of the bolt shows signs of wear, or firing pin hole has become enlarged, the bolt should be replaced.

(b) The extractor should be replaced if it becomes deformed and does not extract the cartridge properly.

(c) If the nose of the firing pin becomes worn or deformed, the firing pin should be replaced.

(5) *Lock.*—It is of extreme importance that the lock be in good condition with all sliding surfaces smooth and polished, otherwise repair or replacement is necessary.

(6) *Oiler group.*—If the oiler is deformed so as to interfere with action of recoiling parts, it should be replaced. If the oil pads are dirty or do not absorb oil properly, replace the oiler.

(7) *Buffer group and recoil spring.*—(a) If the buffer pilot or the pad should be deformed to the extent of hindering proper functioning of the gun, they should be replaced.

(b) If the recoil spring is kinked or set, it should be replaced.

d. *Magazines, box and drum type.*—If the springs are weak, they must be replaced. In the drum magazine, the entire rotor should be replaced. If the magazines are deformed so they will not lock in the gun properly or prevent proper action of the spring, the faulty part should be replaced. If the lips are bent or out of true or deformed so they do not feed cartridges to the gun properly and cannot be repaired, the part should be replaced.

15. *Care and cleaning.*—a. It is of great importance that the matériel be kept absolutely clean and ready for inspection or use at all times. Special attention should be given to dirty magazines. After firing, clean the bore, chamber and all parts, and surfaces of the receiver, bolt ejector, and extractor that have come in contact with powder gases. Remove the frame from the receiver and take out the bolt, and thoroughly clean front end of the bolt and the extractor. With the bolt removed, the bolt well, throat of the receiver, and ejector head are readily accessible.

b. The bore is best cleaned with Cleaner, rifle bore, as prescribed in TM 9-850 in sections entitled "Cleaners and Preservatives," and "Lubricants." When rifle bore cleaner is not available, soap and water should be used as prescribed in FM 23-40. For material used in care and preservation of the gun, refer to TM 9-850 and SNL K-1.

16. *Care and cleaning in Arctic climates.*—For special care and cleaning of the gun in Arctic climates, refer to TM 9-850, section on "Lubricants."

17. *Lubrication.*—The gun should be kept thoroughly lubricated at all times. The felt pads in the breech oiler should be kept well saturated with oil. However, the oil contained and distributed by the felt pads is not sufficient in instances of prolonged firing, so all sliding

surfaces should be oiled frequently and freely to insure perfect functioning of the gun. For proper instruction in the lubricating of the gun, refer to FM 23-40, and for material used, TM 9-850 and SNL K-1.

18. *Matériel affected by gas.*—For defense against chemical attack, and for procedure to be followed in the care of matériel affected by gas, refer to FM 21-40 and TM 9-850.

SECTION V

REFERENCES

	Paragraph
Standard Nomenclature Lists.....	19
Explanatory publications	20
19. Standard Nomenclature Lists.	
a. Ammunition, revolver and automatic pistol.....	SNL T-2
b. <i>Cleaning and preserving.</i>	
Cleaning, preserving and lubricating material, recoil fluids, special oils, and similar items of issue.....	SNL K-1
Soldering, brazing, and welding materials, and related items.....	SNL K-2
c. <i>Gun matériel.</i>	
Gun, submarine, cal. .45, Thompson, M1928A1.....	SNL A-32
Tools, special repair, automatic guns, automatic gun matériel, automatic and semiautomatic cannon and mortars.....	SNL A-35
Truck, small arms, repair, M1.....	SNL G-72
Current Standard Nomenclature Lists are as tabulated here. An up-to-date list of SNL's is maintained as the "Ordnance Publications for Supply Index".....	OPSI
20. Explanatory publications.	
a. Ammunition, general.....	TM 9-1900
b. <i>Cleaning, preserving, lubricating, and welding materials, and similar items issued by the Ordnance Department.</i>	TM 9-850
c. <i>Gun matériel.</i>	
Defense against chemical attack.....	FM 21-40
Ordnance maintenance procedure—Matériel inspection and repair.....	TM 9-1100
Thompson submachine gun, cal. .45, M1928A1.....	FM 23-40

INDEX TO TEXT

A	Page	Drum magazine—Continued.	Page
Actuator, inspection of	14	inspection of	14
Arctic climates, care of gun in	20	maintenance and repair of	20
		rotor	14
		spring case	18
		F	
B		50-round magazine (<i>see</i> Drum magazine).	
Barrel, how to remove	19	Fire control lever, setting	1
Barrel group:		Foregrip group, inspection of	12
illustrated disassembled	11	Frame:	
inspection of	12	inspection of	8
maintenance and repair of	19	maintenance and repair of	19
Bolt group:		Frame group:	
illustrated disassembled	15	caution in disassembling	8
inspection of	13	illustrated disassembled	9
maintenance and repair of	19	inspection of	8
Bore, cleaning of	20	maintenance and repair of	19
Box magazine (20 rounds):		parts composed of	19
illustrated:		Front sight, assembly of to new barrel	19
attached to gun	2		
disassembled	16	G	
inspection of	14	Gas, matériel affected by	21
maintenance and repair of	20	Groups, gun assembly divided:	
tube, inspection of	14	into	4
Buffer group:		illustrated	5
inspection of	14		
maintenance and repair of	20	I	
Bulge in barrel	12	Inspection of gun	6
Burs, removing from smooth surfaces	18	actuator	14
Butt stock assembly:		barrel group	12
illustrated disassembled	7	bolt group	13
inspection of	8	box magazine	14
maintenance and repair of	19	buffer group	14
		butt stock assembly	8
C		drum magazine	14
Care of gun	20	foregrip group	12
Cleaner, rifle bore	20	frame	8
Cleaning of gun	20	frame group	8
Compensator, "Cutts":		gun as unit	6
assembly of to new barrel	19	lock	14
removing	12	magazines	14
		magazine catch assembly	8
D		oiler group	14
Drum magazine (50 rounds):		pivot plate assembly	10
illustrated:			
attached to gun	3		
disassembled	17		

INDEX TO TEXT

	Page		Page
Inspection of gun—Continued.			
purpose of	6	O	
rear sight group	12	Oiler group:	
receiver group	10	inspection of	14
recoil spring	14	maintenance and repair of ..	20
report on	6	Operation of gun, described	4
rocker	8	P	
rocker pivot	10	Parts, gun, when to replace	18
safety	8	Pits in barrel	12
sear group	10	Pivot plate assembly:	
tools for	6	inspection of	10
trigger group	10	maintenance and repair of ..	19
L		Primer, set back, causes of	13
Lands, worn	12	R	
Lock:		Rear sight group:	
inspection of	14	illustrated disassembled	13
maintenance and repair of ..	20	inspection of	12
Lubrication of gun	20	maintenance and repair of ..	19
M		Receiver group:	
Magazine, types of	4	illustrated disassembled	11
box (see Box magazine).		inspection of	10
drum (see Drum magazine).		maintenance and repair of ..	19
Magazine body, inspection of ..	18	parts composed of	4
Magazine catch assembly:		Recoil spring:	
inspection of	8	inspection of	14
maintenance and repair of ..	19	maintenance and repair of ..	20
Magazine tube (box magazine),		removing and replacing	14
inspection of	14	Repair of gun (see Maintenance	
Maintenance and repair of gun ..	18	and repair of gun).	
barrel group	19	Rocker:	
bolt group	19	inspection of	8
buffer group	20	maintenance and repair of ..	19
butt stock assembly	19	Rocker pivot:	
drum magazine	20	inspection of	10
frame	19	maintenance and repair of ..	19
frame group	19	Rotor, and spring case, disas-	
lock	20	sembling	14
magazine	20	S	
oiler group	20	Safety, inspection of	8
pivot plate assembly	19	Screws, removing burs from	18
rear sight group	19	Sear group:	
receiver group	19	illustrated	9
recoil spring	20	inspection of	10
rocker	19	maintenance and repair of ..	19
rocker pivot	19	Serviceability, inspection of bar-	
sear group	19	rel for	12
trigger group	19		
Mechanism of gun, described ..	4		

INDEX TO TEXT

	Page		Page
Sight leaf assembly, removing		Thompson submachine gun—Con.	
and disassembling	13	illustrated	2, 3
Sight slide and catch, removing.	13	inspection of	6
Soap and water, use of in clean-		lubrication of	20
ing	20	maintenance and repair of ..	18
Spring case, and rotor, disassem-		mechanism of	4
bling	18	operation of	4
T		Trigger group:	
Thompson submachine gun, cal.		illustrated	9
.45, M1928A1:		inspection of	10
care and cleaning of	20	maintenance and repair of ..	19
description of	1	20-round magazine (see Box	
gas, affected by	21	magazine).	
		W	
		Windage screw, removing	13

[A. G. 062.11 (12-23-41).]

BY ORDER OF THE SECRETARY OF WAR:

G. C. MARSHALL,
Chief of Staff.

OFFICIAL:

E. S. ADAMS,
Major General,
The Adjutant General.

DISTRIBUTION: Bn 9 (1); IC 9 (3).

(For explanation of symbols see FM 21-6.)